

PROGUARD Gastronomy 200



The All-In-One solution for professional kitchen equipment

With its efficient reverse osmosis (RO) technology, the PROGUARD Gastronomy 200 provides high quality RO filtered water for your oven and delivers total demineralized water for your dishwasher applications. Impressing by a high performance and a powerful flow rate, this filter system fulfills all conditions and needs of professional kitchens as it is able to handle all incoming waters. The PROGUARD Gastronomy 200 is the professional one fits all solution that removes particles reliably from the machine and the end product to ensure smooth operation for your business. It protects your application not only against lime scale but also against gypsum and corrosion – even at fluctuating water demands.

Typical application areas for the PROGUARD Gastronomy are combi steamers, baking ovens and dishwashers.

The benefits to you

- Significantly reduced machine downtimes due to two premium RO-membranes with a salt retention rate $\geq 97\%$, which reliably protect your machine from corrosion, lime scale and gypsum deposits
- Covers from low water demands with peaks to constantly high demands
- Individual mineralization level through adjustable blending of raw water based on your machine's individual specifications
- High performing system with sufficient flow rate of 140 l/h (at 15° C inlet water temperature) and 200 l/h (at 25° C)
- Equipped with an easy to use display, showing all relevant performance data at a glance
- Easy handling and operation due to an electrical RO system with rotary valve pump



BRITA Professional Filter Service App

The Filter Service App is your ideal assistant. This unique, comprehensive tool helps determine the right type and size of filter for your precise needs. It provides detailed installation guidance for service engineers, calculates when cartridges will need replacing – and has a wealth of other, innovative capabilities.

Download for free on



Or visit <https://professional.brita.net/app>

Powerful and high capacity filtration in 5 steps

- 1 Pre-filtration**
Carbon block filtration retains coarse particles and protects the two reverse osmosis (RO) membranes. It filters out taste and odour impairing substances.
- 2 RO membranes**
Two premium RO membranes reliably safeguards against corrosion, scale, gypsum and other contaminants from entering the machines.
- 3 Bypass**
The valve bypass adjustment provides machine-based mineralization levels.
- 4 Display**
The build-in display shows all relevant parameters such as pressure, flow rate and conductivity of the filtrate.
- 5 Pump**
An electrical RO system with rotary valve pump ensures high performance, easy handling and essential reliability.

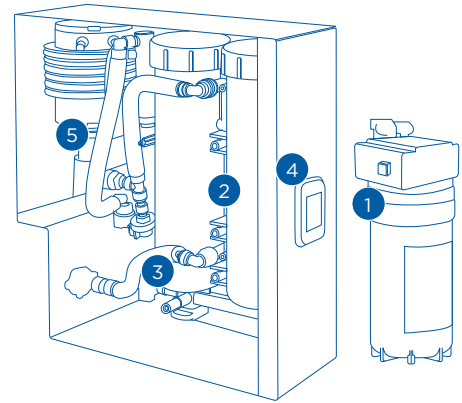

The illustration serves as explanation of the filter technology. It is not to scale.

PROGUARD Gastronomy 200	
Technology	Reverse osmosis, activated carbon filtration
Capacity ¹	Pre-Filter: 500,000 l
Membrane	500 GPD (gallons per day)
Min. / Max. operating pressure	1-6 bar
Water intake temperature	4 - 35 °C
Flow rate at 25 °C (at 15 °C)	200 l/h (140 l/h)
Power supply	220 VAC 50 Hz
Dimensions (W/D/H) of system	14.5/41/43 cm
Dimensions (W/D/H) of pre-filter	21/17/41 cm
Weight of system	16.2 kg
Water inlet and outlet connections	G 3/4"
Operating position	Horizontal or vertical
PROGUARD Gastronomy 200	Order number
Starter Set PROGUARD Gastronomy 200 (RO system, pre-filter, filterhead, install kit)	1053696
Refill cartridges	Order number
Pack 1 pre-filter PROGUARD Gastronomy 200	1053363
Pack 2 membrane PROGUARD Gastronomy 200	1053442
Tank	Order number
Tank install kit PROGUARD Gastronomy 200	1053698
8 L Tank PROGUARD Gastronomy	1053755
18 L Tank PROGUARD Gastronomy	1053756
Spare Parts	Order number
PROGUARD Gastronomy 200 RO system	1053368
Filter head PROGUARD Gastronomy 200	1053366
Install Kit PROGUARD Gastronomy 200	1053697
Solenoid valve PROGUARD Gastronomy 200	1053661
Control unit display PROGUARD Gastronomy 200	1053662
TFT display PROGUARD Gastronomy 200	1053663
Pressure sensor pump PROGUARD Gastronomy 200	1053664
Pressure sensor permeate PROGUARD Gastronomy 200	1053665
Pressure sensor inlet PROGUARD Gastronomy 200	1053666
Motor PROGUARD Gastronomy 200	1053667
Pump PROGUARD Gastronomy 200	1053668

Appropriate hoses and hose sets from our comprehensive FlexConnect range as well as other accessories can be found in our price list.

Explanatory notes ¹The capacities given have been tested and calculated on the basis of normal application and machine conditions. Due to external influences (e.g. variations in raw water quality and/or machine type), deviations from these results can occur.

Only drinking water quality may be used as the water supply for BRITA water filters.

For more information please contact:

BRITA Nordic A/S
 Centervej 32 | 4180 Sorø | Denmark
 Tel.: +45 7027 3266
 britanordic@brita.net | www.brita.dk

Headquarters: BRITA SE
 Heinz-Hankammer-Straße 1 | 65232 Taunusstein | Germany
 Tel.: +49 6128 746-0 | Fax: +49 6128 746-5033
 info@brita.net | www.brita.de